

Mattira Combi



Digital modulating electric boiler, for heating and domestic hot water.

5 Years* Guarantee

- Safe and reliable
- Cost effective
- Energy efficient
- Smart Electronic Modulating System (SEM)
- No risk of leaks or explosions
- ErP Compliant

MAC15
Wall mounted



Technical Features

- Heating boiler made of insulated steel.
- Modulating electronic control of the heater by SEM system (Smart Electronic Modulating system).
- 50L DHW tank made of insulated stainless steel, CFC free.
- Stainless steel shielded elements - INCOLOY800 for heating and DHW.
- 6L heating expansion vessel.
- 3L DHW expansion vessel.
- Modulating electronic control of the heater.
- Pressure gauge 0-4bar.
- Circulating pump.
- Auto air vent.
- Silent TRIAC power switches.
- Auto Heating Regulation mode.
- Heating flow detector.
- Heating temperature limiter 100°C.
- DHW temperature limiter 80°C.
- Heating 3 bar relief valve.
- DHW 7 bar relief valve.
- Also suitable for use with under floor heating.
- DHW anti-electrolysis hoses.
- Powder coated RAL 9010.
- Wall bracket steel template to set up connections easily.
- Compatible with the Elnur "RSTAT" Ambient Thermostat and the Elnur Connected range of internet thermostats, all available as accessories.

*Full warranty terms and conditions available at www.elnur.co.uk

Mattira Combi MAC15 Specifications

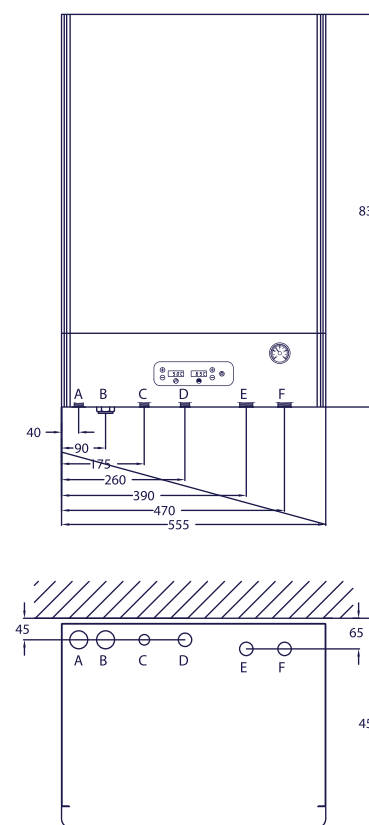

Dimensions and connections:

- A - Safety valve drain DHW
- B - Electrical connection
- C - Cold water input 1/2"
- D - DHW outlet 1/2"
- E - Heating return 3/4"
- F - Heating flow 3/4"

Wall mounted

Model	MAC15											
Selectable Output (kW)	3	4	5	6	7	8	9	10	11	12	13	15
kcal/h	2580	3440	4300	5160	6020	6880	7740	8600	9460	10320	11180	12900
Current 3 x 400 V+N- A	13.0	8.7	13.0	8.7	13.0	13.0	13.0	21.7	21.7	21.7	21.7	21.7
**Current 230 V- A	13.0	17.4	21.7	26.1	30.4	34.8	39.1	43.5	47.8	52.2	Ask	Ask
***Time Available DHW (min)	29'04"	21'48"	17'26"	14'32"	12'27"	10'54"	9'41"	8'43"	7'56"	7'16"	6'42"	5'49"

Using included bridge connection *Time in minutes remaining available on DHW

Model	MAC15
Voltage (V)	3x400 V+N / 220-240
Frequency (Hz)	50-60
Insulation	Class 1
Net weight (kg)	61
Dimensions (HxWxD)	83cm x 55.5cm x 45cm
EAN 13	8432336804663